

Slim Dual Range Power Head with Germanium Detector



S132C

Description

The S132C with its slim design of only 5mm at the detector side is perfect to fit into tight optical setups. The ruggedized aluminum head with its large active area silicon photodiode can be held by hand or can be mounted with its 8-32 and M4 threaded mounting holes to posts and post holders.

A slideable ND filter enlarges the power range by approximately factor 100; the position of the filter is automatically recognized by the connected console after a few seconds for calculating the power level with the right responsivity value.

The S132C is compatible with all new Thorlabs display units. A non-volatile memory in the sensor connector contains sensor information data and the NIST and PTB traceable calibration data.

Available Accessories

SM1A29	SM1 thread adapter with alignment target
S120-FC	FC fiber adapter
S120-SMA	SMA fiber adapter
S120-SC	SC fiber adapter
S120-LC	LC fiber adapter
S120-ST	ST fiber adapter

The S132C is also compatible to the Thorlabs imperial and metric post and post-holder series and with the optional thread adapter to Thorlabs SM1 mechanics.

Cleaning and Maintenance

There are no serviceable parts in the S132C head. The housing may be cleaned by wiping with a soft damp cloth. When cleaning the aperture filter, treat it as any other fine optic. Gently blow off any debris using compressed air and wipe gently with an optic tissue wetted with propanol. If you suspect a problem with your S132C please call Thorlabs and an engineer will be happy to assist you.

As long as the sensor has not been exposed to excessive optical power (please pay attention to the maximum ratings in the technical specifications), the calibration should be very stable over long periods of time (well over a year). To keep the accuracy and performance of the S132C, Thorlabs recommends a yearly recalibration, starting one year after purchase.

Specifications

Detector Type	Germanium Photodiode
Wavelength Range ³⁾	700 - 1800 nm
Optical Power Working Range	5 nW - 5 mW (500 mW with filter)
Max Average Power Density	10 W/cm ²
Max Pulse Energy	20 μJ
Linearity	± 0.5%
Resolution ¹⁾	1 nW
Measurement Uncertainty ²⁾	±5%
Typical Application	Low Power Lasers
Laser Types	Diode, Diode Arrays, He-Ne, Dye, Ion Lasers (Ar+, Kr+)
Coating /Diffuser ³⁾	Absorptive ND (Schott NG9/KG3)
Cooling	Convection
Console Compatibility	PM100D, PM100A, PM100USB, PM200, PM320E
Response Time	< 1 μs
Sensor Dimensions	150 mm x 19 mm x 10 mm 5 mm thickness on sensor side
Active Detector Area	9.7 mm x 9.7 mm
Input Aperture	Ø9.5 mm
Cable Length	1.5 m
Connector	Sub-D 9p male
Weight	0.125kg
Post	#8-32 & M4 threads
Aperture Thread (optional)	SM1, outer thread with SM1A29 adapter
Fiber Adapters (optional)	FC, SC, LC, SMA, ST (SM1A29 adapter required)

¹⁾ Measured with PM100D console in bandwidth low setting @ 1550nm, without filter.

²⁾ Beam diameter > 1mm

³⁾ This specification is valid for S132C devices from serial number 1203xxx. For older versions, please contact technical support.

Please note that the S132C power meter head is not compatible with the older Thorlabs power meter consoles (PM100, PM30, PM300, PM300E, S100).

Typical Response Graph

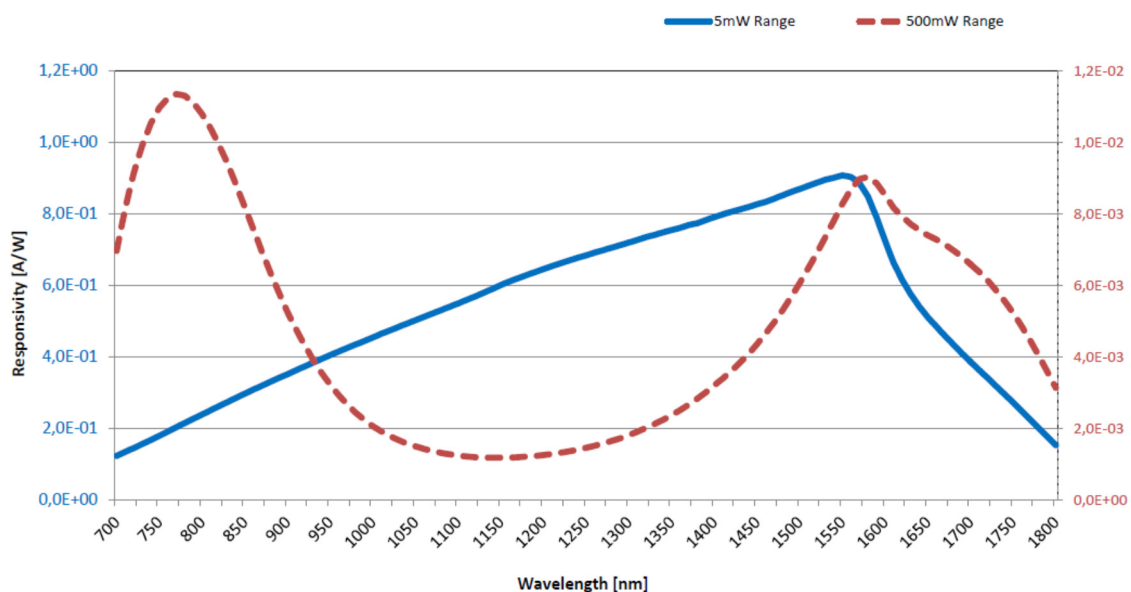

Drawings

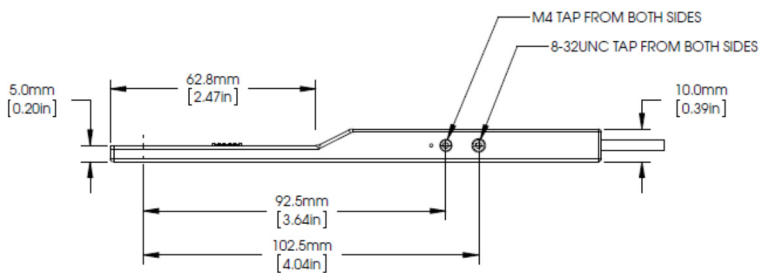
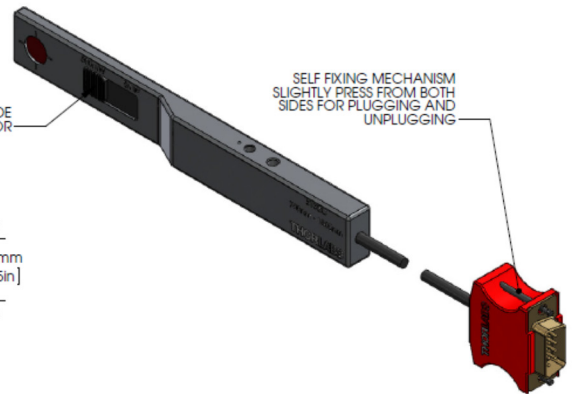
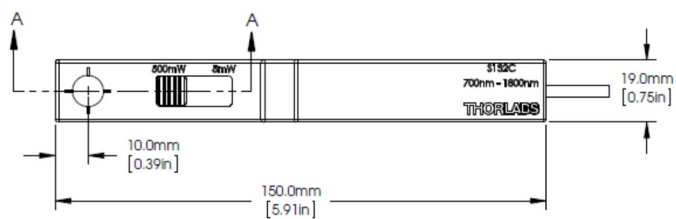
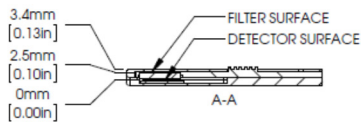

CONNECTOR PIN DIAGRAM

2	EEPROM DATA
3	PD ANODE
4	PD KATHODE
6	EEPROM GROUND
7	SLIDER DETECTION
1,4,5,9	N.C.

Precautions and Warranty Information

These products are ESD (electro static discharge) sensitive and as a result are not covered under warranty. In order to ensure the proper functioning of a photodiode care must be given to maintain the highest standards of compliance to the maximum electrical specifications when handling such devices. The photodiodes are particularly sensitive to any value that exceeds the absolute maximum ratings of the product. Any applied voltage in excess of the maximum specification will cause damage and possible complete failure to the product. The user must use handling procedures that prevent any electro static discharges or other voltage surges when handling or using these devices.

Thorlabs, Inc. Life Support and Military Use Application Policy is stated below:

THORLABS' PRODUCTS ARE NOT AUTHORIZED FOR USE AS CRITICAL COMPONENTS IN LIFE SUPPORT DEVICES OR SYSTEMS OR IN ANY MILITARY APPLICATION WITHOUT THE EXPRESS WRITTEN APPROVAL OF THE PRESIDENT OF THORLABS, INC. As used herein:

- 1. Life support devices or systems are devices or systems which, (a) are intended for surgical implant into the body, or (b) support or sustain life, and whose failure to perform, when properly used in accordance with instructions for use provided in the labeling, can be reasonably expected to result in a significant injury to the user.*
- 2. A critical component is any component in a life support device or system whose failure to perform can be reasonably expected to cause the failure of the life support device or system or to affect its safety or effectiveness.*
- 3. The Thorlabs products described in this document are not intended nor warranted for usage in Military Applications.*

